



* Two Horse Model



STANDARD FEATURES

- 7' Wide (6'8" Inside) 7' Tall
- Catalyzed Polyurethane Paint / Catalyzed Two-Part Primer
- Galvanized Roof Bows / Sheeting
- Pre-Primered Tubing
- Vinyl Front & Rear Stripe Detailing
- Aluminum Diamond Plate Over Front & Fender
- Exterior Caulking
- Rubber Dock Bumper
- Telescoping Padded Divider
- 4 Wheel Electric Brakes
- Diagonal Load
- Removable Diagonal Wall

Caulking Package Highly Recommended

AVAILABLE IN TWO, THREE & FOUR HORSE BUMPER PULL OR GOOSENECK MODELS

Bigger is Better...When it's not the price!



SPECIFICATIONS

2 HORSE MODEL

3 HORSE MODEL

4 HORSE MODEL

INSIDE HEIGHT.....	7'	7'	7'
OVERALL HEIGHT.....	8'3"	8'4"	8'4"
INSIDE WIDTH.....	6'8"	6'8"	6'8"
OVERALL WIDTH.....	8'5"	8'5"	8'5"
FLOOR HEIGHT.....	14"	15"	15"
OVERALL LENGTH.....	16'3"	20'3"	22'3"
TRAILER BODY LENGTH.....	12'10"	16'10"	19'
TANDEM AXLES.....	3500#	*5200#	5200#
WHEELS.....	White Modular 5-Lug.....	White Modular 6-Lug.....	White Modular 6-Lug
TIRES.....	ST205/75-15/LR-C.....	ST225/75-15/LR-D.....	ST225/75-15/LR-D
COUPLER.....	2 5/16" Bulldog.....	2 5/16" Bulldog.....	2 5/16" Bulldog
BRAKES.....	10" - 4 Wheel Electric.....	12" - 4 Wheel Electric.....	12" - 4 Wheel Electric
EMPTY WEIGHT.....	2425#.....	3475#.....	3675#
HITCH WEIGHT.....	300#.....	425#.....	525#
PAYLOAD CAPACITY.....	4575#.....	6524#.....	6324#
INTERIOR LIGHTS.....	(2) 1 Horse Stall & 1 Tack Room.....	(2) 1 Horse Stall & 1 Tack Room.....	(2) 1 Horse Stall & 1 Tack Room
BLANKET BARS.....	(2).....	(2).....	(2)
BRIDLE HOOKS.....	(6).....	(6).....	(6)
SADDLE RACKS.....	(2) Racks / Stationary.....	(3) Racks / Stationary.....	(4) Racks / Stationary
ALUMINUM DIAMOND PLATE.....	Front & Fender Overlay.....	Front & Fender Overlay.....	Front & Fender Overlay
RUBBER DOCK BUMPER.....	3" Rear.....	3" Rear.....	3" Rear
ROOF BOWS.....	w/ Flow Coat Galvanized.....	w/ Flow Coat Galvanized.....	w/ Flow Coat Galvanized
FRONT BOWS.....	Pre-Primered Steel.....	Pre-Primered Steel.....	Pre-Primered Steel
ELECTROGALVANIZED SHEET METAL.....	#3 Galvanized Finish.....	#3 Galvanized Finish.....	#3 Galvanized Finish
LOCKABLE REAR DOOR.....	Single Open.....	Single Open.....	Single Open
ANGLE WALL.....	Removable.....	Removable.....	Removable
PADDED DIVIDERS.....	(1).....	(2).....	(3)
VINYL PACKAGE.....	Standard.....	Standard.....	Standard

*Standard features are subject to change without notification.

*Can be ordered with 3500# Axles



TWO HORSE MODEL

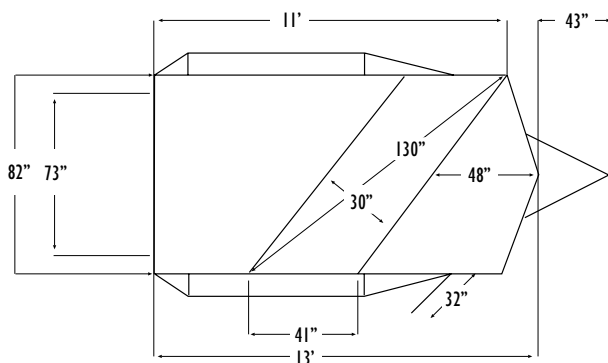

THREE HORSE MODEL

