



\* Two Horse Model



## STANDARD FEATURES

- 7' Wide (6'8" Inside) 7' Tall
- Catalyzed Polyurethane Paint / Catalyzed Two-Part Primer
- Galvanized Roof Bows / Sheeting
- Pre-Primered Tubing
- Vinyl Front & Rear Stripe Detailing
- Full Outside Caulking
- Removable Diagonal Wall
- Padded Divider
- Aluminum Diamond Plate Over Front & Fender
- Small Tack & Side Door

Caulking Package Highly Recommended

AVAILABLE IN TWO AND THREE HORSE BUMPER PULL MODELS ONLY

*Bigger is Better...When it's not the price!*



**SPECIFICATIONS**

**2 HORSE MODEL**

**3 HORSE MODEL**

INSIDE HEIGHT.....	7'	7'
OVERALL HEIGHT.....	8'3"	8'3"
INSIDE WIDTH.....	6'8"	6'8"
OVERALL WIDTH.....	8'5"	8'5"
FLOOR HEIGHT.....	14"	14"
OVERALL LENGTH.....	13'9"	17'3"
TRAILER BODY LENGTH.....	10'2"	13'10"
TANDEM AXLES.....	3500#	3500#
WHEELS.....	White Modular 5-Lug.....	White Modular 5-Lug
TIRES.....	ST205/75-15/LR-C.....	ST205/75-15/LR-C
COUPLER.....	2 5/16" Bulldog.....	2 5/16" Bulldog
BRAKES.....	10" - 4 Wheel Electric.....	10" - 4 Wheel Electric
EMPTY WEIGHT.....	2100#.....	2400#
HITCH WEIGHT.....	275#.....	325#
PAYLOAD CAPACITY.....	4900#.....	4600#
BRIDLE HOOKS.....	(6).....	(6)
BLANKET BARS.....	(2).....	(2)
ALUMINUM DIAMOND PLATE.....	Front & Fender Overlay.....	Front & Fender Overlay
ROOF BOWS.....	w/ Flow Coat Galvanized.....	w/ Flow Coat Galvanized
FRONT BOWS.....	Pre-Primed Steel.....	Pre-Primed Steel
ELECTROGALVANIZED SHEET METAL.....	#3 Galvanized Finish.....	#3 Galvanized Finish
LOCKABLE REAR DOOR.....	Single Open.....	Single Open
ANGLE WALL.....	Removable.....	Removable
PADDED DIVIDERS.....	(1).....	(2)
VINYL PACKAGE.....	Standard.....	Standard

\*Standard features are subject to change without notification.



**THURO-BILT**

TWO HORSE MODEL

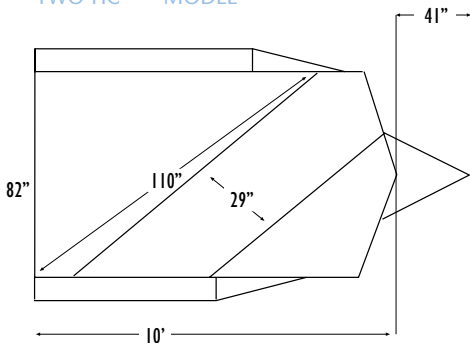

THREE HORSE MODEL

